

**NOTES:**

There is nothing critical on any of these measurements. Make sure all the sawn edges are filed or scraped down to eliminate sharp edges.

| REVISIONS |             |      |
|-----------|-------------|------|
| REV.      | DESCRIPTION | DATE |
|           |             |      |

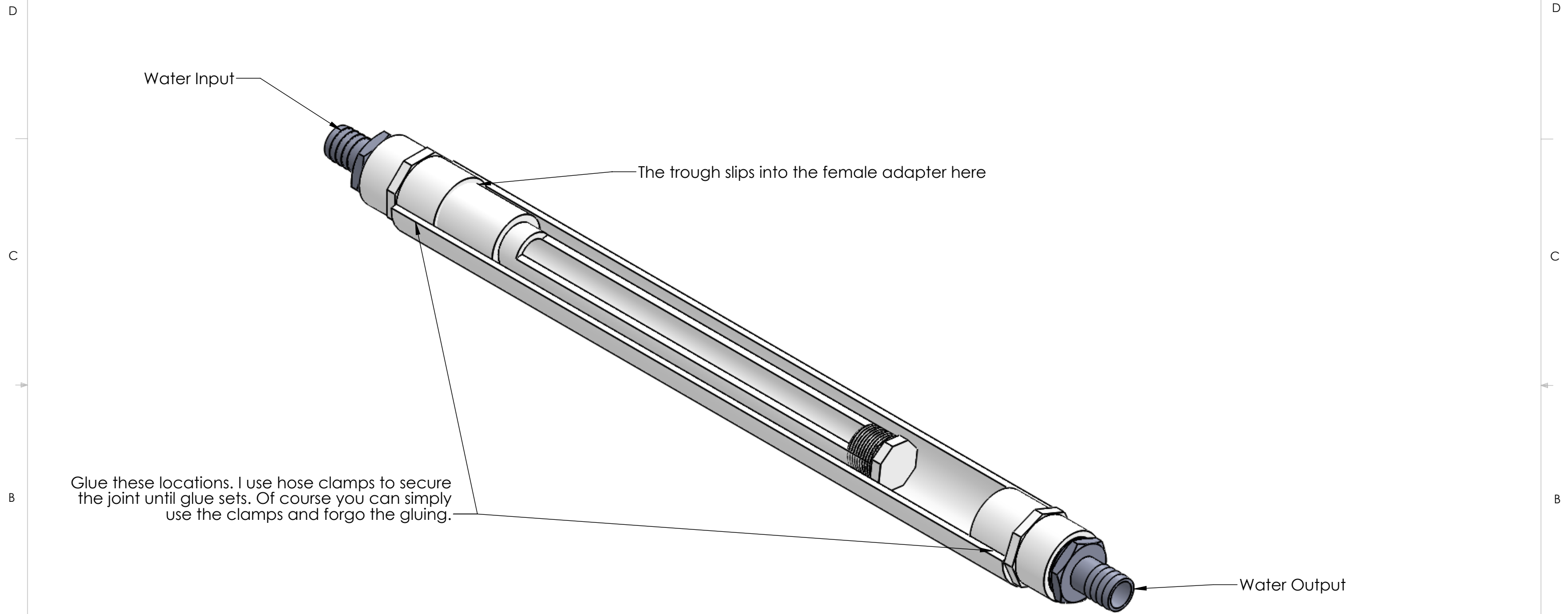

| ITEM NO. | Description    | Name       | Pur Material  | QTY. |
|----------|----------------|------------|---------------|------|
| 1        | Female Adapter | Soc x MPT  | 1" x 1"       | 2    |
| 2        | Barbed Adapter | Barb x MPT | 3/4" x 1"     | 2    |
| 3        | Pipe, PVC,     | Pipe, PVC  | 3/4", SCH80   | 1    |
| 4        | Plug, PVC      | MPT        | 3/4", SCH80   | 1    |
| 5        | Coupling, PVC  | Soc x Soc  | 3/4", SCH80   | 1    |
| 6        | Pipe, PVC,     | Pipe, PVC  | 1 1/2", SCH40 | 1    |

|                                                                                                                                                                                                                     |                       |                    |  |
|---------------------------------------------------------------------------------------------------------------------------------------------------------------------------------------------------------------------|-----------------------|--------------------|--|
| <b>CONFIDENTIAL</b><br>DO NOT USE OR REPRODUCE WITHOUT AUTHORITY OF IGT. COPYRIGHT IGT. ALL RIGHTS RESERVED.                                                                                                        |                       | <b>KowCo</b>       |  |
| UNLESS OTHERWISE NOTED<br>DIMENSIONS ARE IN INCHES<br>TOLERANCES:<br>ANGULAR ± 0.5<br>FILLETS ± 0.005 - 0.200<br>RADIUS ± 0.005 - 0.015<br>MACHINED SURFACE FINISH 3.2<br>.X ± 0.050<br>.XX ± 0.020<br>.XXX ± 0.010 |                       | Chicken Waterer    |  |
| SIZE<br><b>B</b>                                                                                                                                                                                                    | DWG. NO.<br>Top Level | REV.<br><b>1.1</b> |  |
| SCALE:1:2                                                                                                                                                                                                           | DO NOT SCALE DRAWING  | SHEET 1 OF 3       |  |

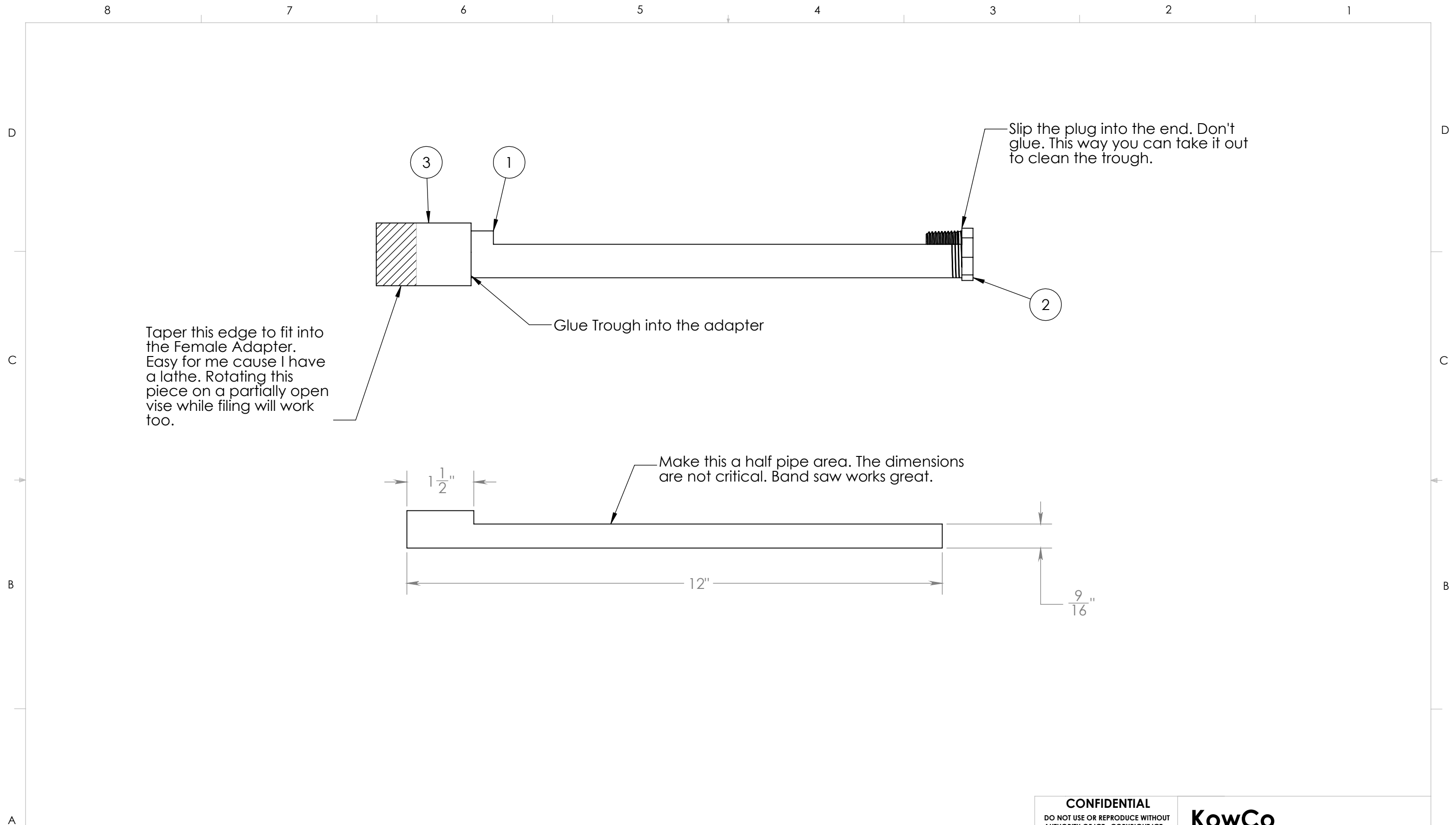

Taper this edge to fit into the Female Adapter. Easy for me cause I have a lathe. Rotating this piece on a partially open vise while filing will work too.

Glue Trough into the adapter

Slip the plug into the end. Don't glue. This way you can take it out to clean the trough.

Make this a half pipe area. The dimensions are not critical. Band saw works great.

1 1/2"

12"

9/16"

| ITEM NO. | Name      | Description   | Pur Material |
|----------|-----------|---------------|--------------|
| 1        | Pipe, PVC | Pipe, PVC,    | 3/4", SCH80  |
| 2        | MPT       | Plug, PVC     | 3/4", SCH80  |
| 3        | Soc x Soc | Coupling, PVC | 3/4", SCH80  |

|                                                                                                                                                                                                                     |                       |                    |  |
|---------------------------------------------------------------------------------------------------------------------------------------------------------------------------------------------------------------------|-----------------------|--------------------|--|
| <b>CONFIDENTIAL</b><br>DO NOT USE OR REPRODUCE WITHOUT AUTHORITY OF IGT. COPYRIGHT IGT. ALL RIGHTS RESERVED.                                                                                                        |                       | <b>KowCo</b>       |  |
| UNLESS OTHERWISE NOTED<br>DIMENSIONS ARE IN INCHES<br>TOLERANCES:<br>ANGULAR ± 0.5<br>FILLETS ± 0.005 - 0.200<br>RADIUS ± 0.005 - 0.015<br>MACHINED SURFACE FINISH 3.2<br>.X ± 0.050<br>.XX ± 0.020<br>.XXX ± 0.010 |                       | Water Trough Assy  |  |
| SIZE<br><b>B</b>                                                                                                                                                                                                    | DWG. NO.<br>Top Level | REV.<br><b>1.1</b> |  |
| SCALE:1:2                                                                                                                                                                                                           | DO NOT SCALE DRAWING  | SHEET 2 OF 3       |  |

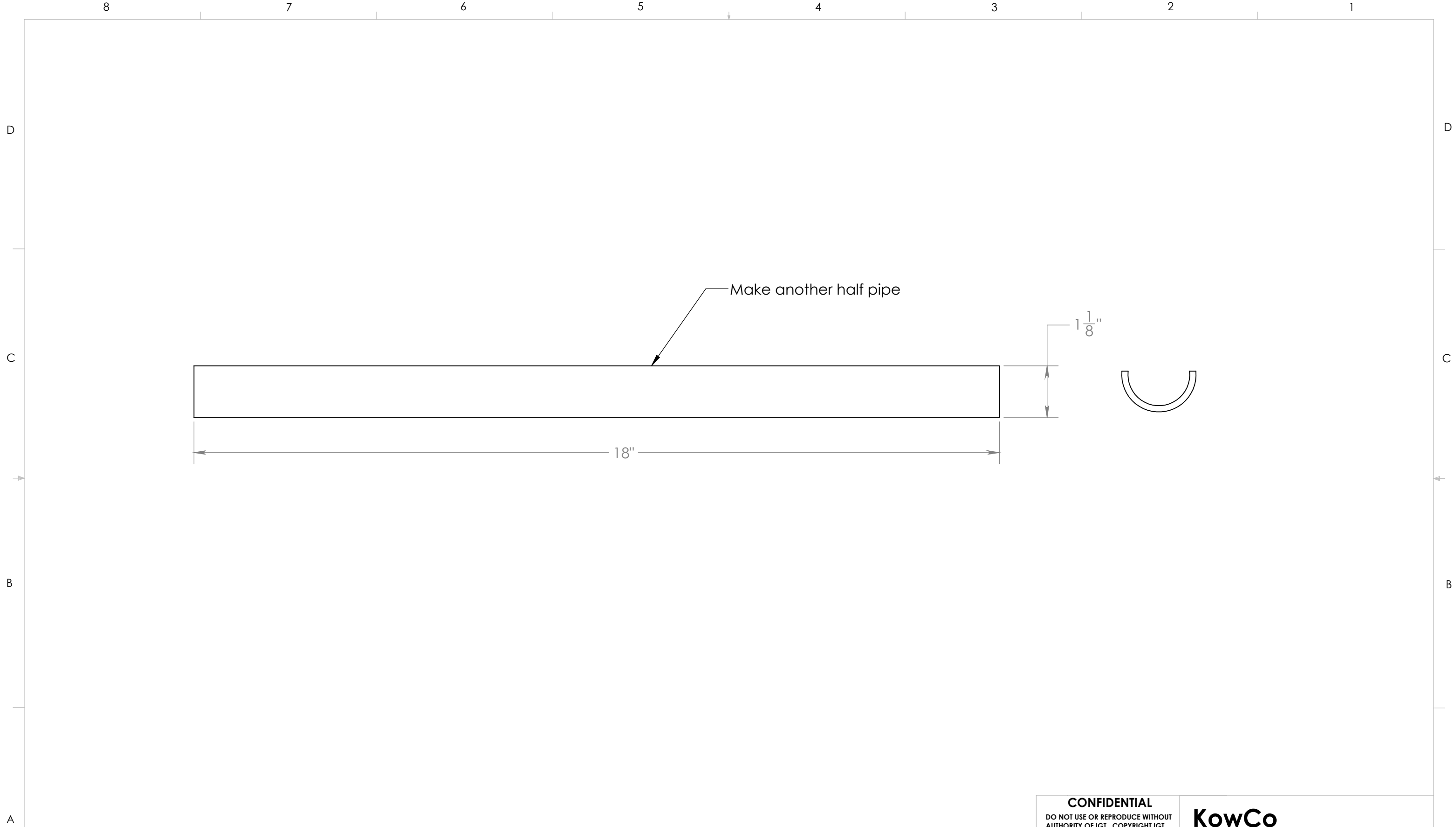

| ITEM NO. | Name      | Description | Pur Material  | QTY. |
|----------|-----------|-------------|---------------|------|
| 1        | Pipe, PVC | Pipe, PVC,  | 1 1/2", SCH40 | 1    |

|                                                                                                                                                                                                                     |                       |                                   |  |
|---------------------------------------------------------------------------------------------------------------------------------------------------------------------------------------------------------------------|-----------------------|-----------------------------------|--|
| <b>CONFIDENTIAL</b><br>DO NOT USE OR REPRODUCE WITHOUT<br>AUTHORITY OF IGT. COPYRIGHT IGT.<br>ALL RIGHTS RESERVED.                                                                                                  |                       | <b>KowCo</b>                      |  |
| UNLESS OTHERWISE NOTED<br>DIMENSIONS ARE IN INCHES<br>TOLERANCES:<br>ANGULAR ± 0.5<br>FILLETS ± 0.005 - 0.200<br>RADIUS ± 0.005 - 0.015<br>MACHINED SURFACE FINISH 3.2<br>.X ± 0.050<br>.XX ± 0.020<br>.XXX ± 0.010 |                       | Pipe, PVC,                        |  |
| SIZE<br><b>B</b>                                                                                                                                                                                                    | DWG. NO.<br>Top Level | REV.<br><b>1.1</b>                |  |
| SCALE:1:2                                                                                                                                                                                                           |                       | DO NOT SCALE DRAWING SHEET 3 OF 3 |  |